

SECTIONAL VIEW
PROLIFT VOYAGER MODEL 4760W

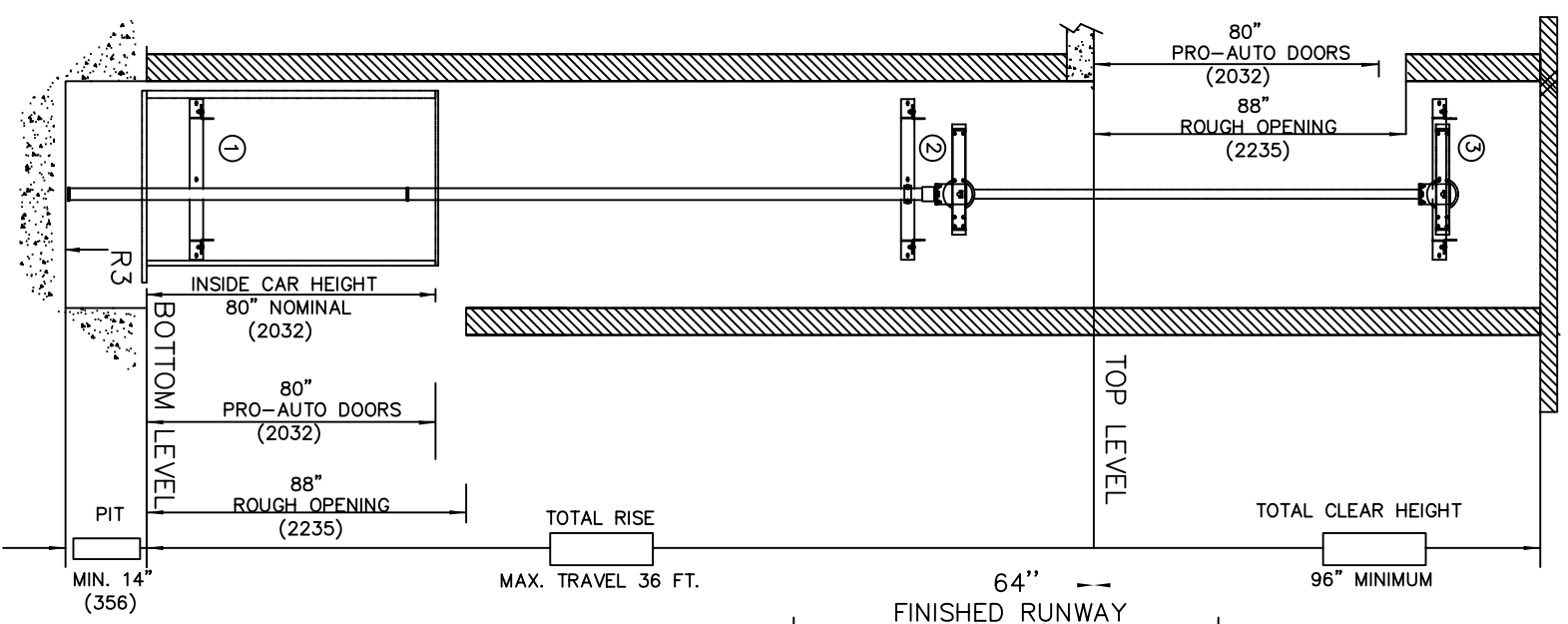

PIT / OVERHEAD REQUIREMENTS			
MAX. SPEED (ft/min)	MIN. PIT TRAVEL	TOTAL TRAVEL	MINIMUM OVERHEAD
30	14" ***	96"(2439)	

*** NOTE: Additional pit equipment required when over 36" deep, consult your local dealer for details

PLAN VIEW -PROLIFT VOYAGER MODEL 4760W

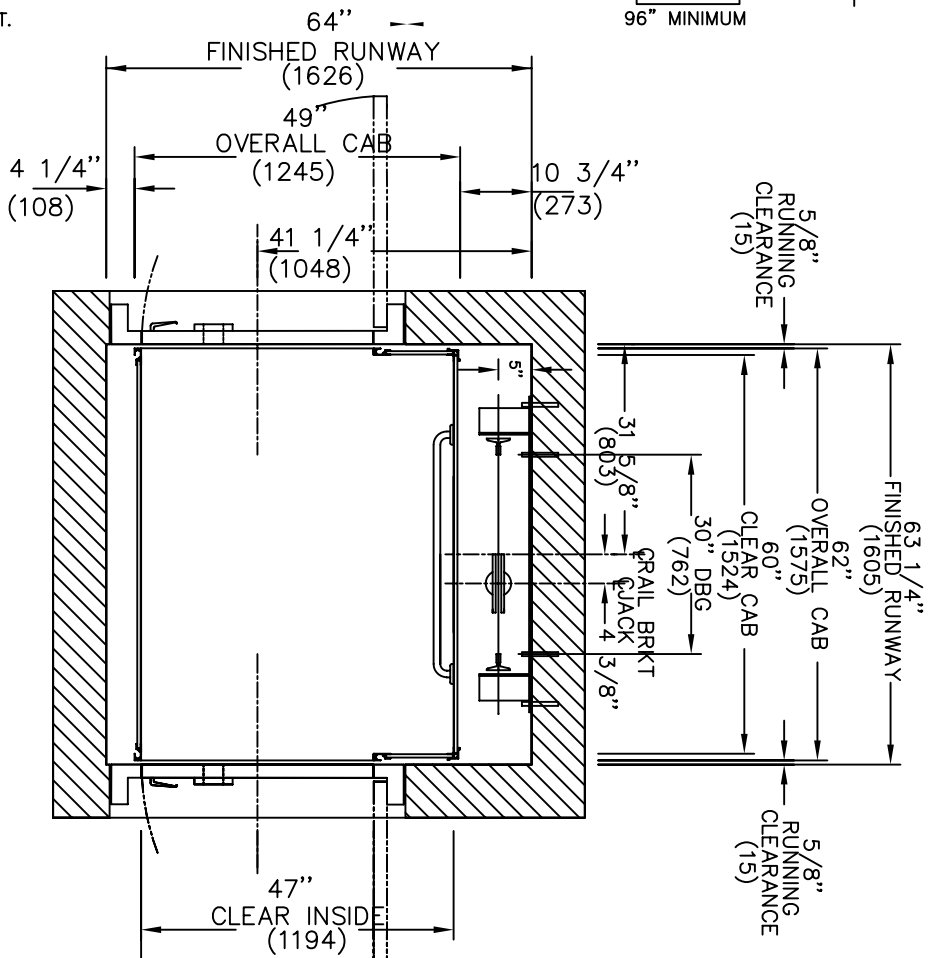

	AT TOP OF HOISTWAY CONSULT YOUR CONCORD REPRESENTATIVE FOR EXACT LOCATION	INTERVALS ABOVE BOTTOM BRACKET	24" ABOVE PIT FLOOR
TOP RAIL BRACKET	(3)	(2)	(1)
INTERMEDIATE RAIL BRACKET			
BOTTOM RAIL BRACKET			

FLOOR NO.	FLOOR HEIGHT	TOTAL RISE
REAR		
FRONT		
TOTAL RISE		

RAIL FORCES			R3 NOTE:	
			PIT FLOOR TO SUPPORT LOAD OF: 8.22klbs * (INCLUDES IMPACT)	
* R1	* R2		FOR TOTAL PULL-OUT FORCE ON RAIL BRACKET, R1 MUST BE DOUBLED eg. 844LBS	
422lbf	180lbf			
RAIL WEIGHT: 8.0 lbs / ft				

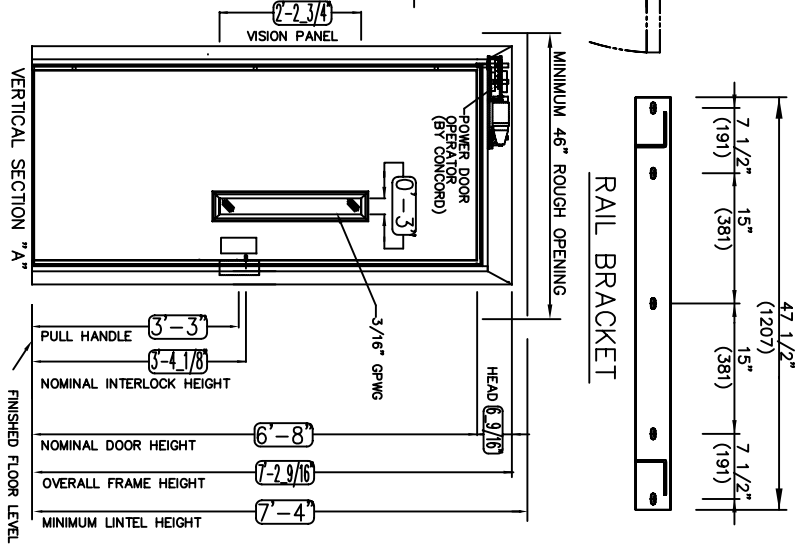

NOTE D:
FLUSH PRO-AUTO DOOR SHOWN

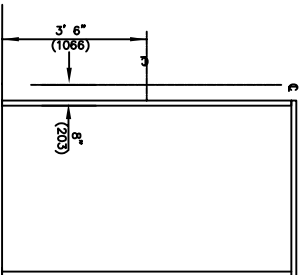

HALL FIXTURE LOCATION
LEFT HAND AS SHOWN
RIGHT HAND OPPOSITE
1. HALL BUTTON AT ALL FLOORS

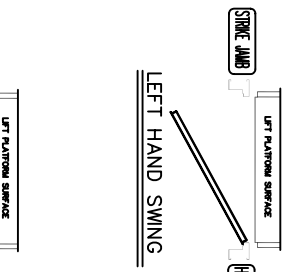

PROVISIONS BY OTHERS

***GENERAL HOISTWAY**- THE HOISTWAY MUST BE IN ACCORDANCE WITH ASME A18.1 / CSA B355-00 AND ALL STATE / PROVINCIAL AND LOCAL CODES.
PLUMB HOISTWAY- DUE TO CLOSE RUNNING CLEARANCES OWNER/AGENT MUST ENSURE THAT HOISTWAY AND PIT (WHERE PROVIDED) ARE LEVEL, PLUMB AND SQUARE AND ARE IN ACCORDANCE WITH THE DIMENSIONS ON THESE DRAWINGS.
MINIMUM OVERHEAD CLEARANCE- OWNER/AGENT MUST ENSURE MINIMUM OVERHEAD CLEARANCE IS IN COMPLIANCE WITH CODES.

CONSTRUCTION SITE- OWNER/AGENT TO PROVIDE ALL MASONRY, CARPENTRY AND DRYWALL WORK AS REQUIRED AND SHALL PATCH AND MAKE GOOD (INCLUDING FINISH PAINTING) ALL AREAS WHERE WALLS/FLOORS MAY REQUIRE TO BE CUT, DRILLED OR ALTERED IN ANY WAY TO PERMIT THE PROPER INSTALLATION OF THE LIFT.

DIMENSIONS
CONTRACTOR/CUSTOMER TO VERIFY ALL DIMENSIONS AND REPORT ANY DISCREPANCIES TO OUR OFFICE IMMEDIATELY.

***STRUCTURAL**
FLOOR/SUPPORT WALL LOADS- STRUCTURAL ENGINEER TO ASSURE THAT BUILDING AND SHAFT WILL SAFELY SUPPORT ALL LOADS IMPOSED BY THE LIFT EQUIPMENT. REFER TO THE TABLES ON THIS DRAWING FOR LOADS IMPOSED BY THE EQUIPMENT.

WHERE DOORS ARE REQUIRED- SUITABLE LINTELS MUST BE PROVIDED BY OWNER/AGENT. DOOR FRAMES ARE NOT DESIGNED TO SUPPORT OVERHEAD WALL LOADS.

***MACHINE ROOM LOCATION / ACCESS**- MACHINE ROOM LOCATED AT THE LOWEST LEVEL ADJACENT TO HOISTWAY, UNLESS SHOWN OTHERWISE ON THE LAYOUT DRAWINGS. FIELD ADJUSTMENT BY INSTALLER MAY BE NECESSARY TO MEET JOB SITE CONDITIONS OR REGULATIONS. ACCESS TO MACHINE ROOM TO BE THROUGH A SELF CLOSING LOCKABLE DOOR.
SLEEVES FOR OIL & ELECTRIC LINES- FROM MACHINE ROOM TO RUNWAY AS REQUIRED. (POSITION PER INSTALLERS INSTRUCTIONS).

MOTOR & EQUIP CAB LIGHTS	DELAY FUSE SIZE	VOLTS	PHASE	AMPERAGE
20AMPS/30AMPS	20AMPS	208V/230V	3PH/1PH	10.6AMPS/17AMPS
15 AMPS	15 AMPS	115 V	1	

***ELECTRICAL POWER SUPPLY**- (SEE SPECIFICATIONS) LOCKABLE FUSED DISCONNECT WITH AUXILIARY CONTACT TO BRAKE THE BATTERY FEED, OR CIRCUIT BREAKERS WITH A 3-POLE BREAKER FOR BATTERY FEED REQUIRED. IN COMPLIANCE WITH ELECTRICAL CODE, AS FOLLOWS:
(LOCATED ON WALL ON LOCK JAMB SIDE OF MACHINE ROOM DOOR) PERMANENT POWER- BEFORE INSTALLATION CAN BEGIN, PERMANENT POWER MUST BE SUPPLIED.
LIGHTING- OWNER/AGENT TO ENSURE AT LEAST 5 FTC OR 54 LUX AMBIENT LIGHTING OVER LIFT AREA.
***ENTRANCES**
FASCIA PANEL BELOW UPPER LEVEL ENTRANCE- WHERE REQUIRED, FASCIA PANEL MUST BE FASTENED TO A SOLID WALL AND BE PERPENDICULAR TO THE FLOOR AND WALLS. HOISTWAY FASCIA IS NOT SELF-SUPPORTING FOR LONG, CONTINUOUS RUNS VOID OF ENTRANCES. ADEQUATE SUPPORT FOR THE FASCIA MUST BE PROVIDED.
ENTRANCE ASSEMBLIES- ENTRANCE ASSEMBLIES MUST BE ADJUSTED TO ALIGN WITH PLATFORM AND INTERLOCK EQUIPMENT. OTHERS TO ALLOW AN ADEQUATE ROUGH OPENING.
RETURN WALLS- RETURN WALLS AT ENTRANCES MUST BE BUILT-IN BY OTHERS AFTER ENTRANCE ASSEMBLIES ARE IN PLACE. ENTRANCE ASSEMBLY MUST BE SECURELY FASTENED TO WALLS BY ELEVATOR CONTRACTOR.

NOTE B
ALL INFORMATION IS SUBJECT TO CHANGE.
PLEASE REFERENCE OUR ON-LINE DRAWINGS AT www.concordlevator.com FOR THE MOST RECENT UPDATES

COMMERCIAL WHEELCHAIR LIFT
PROLIFT VOYAGER MODEL 4760W

CUSTOMER: _____ PROJECT: _____ LOCATION: _____
DATE: _____ REVISION DATE: _____ COMPLETED BY: _____
JOB No. _____ SHEET No. _____

